



Fitting Instructions

FR855

FORD FOCUS ESTATE
1998 TO DECEMBER 2004 (EXC RS)

Bolt Kit

WB	4	10MM LARGE ROUND WASHERS
WA	4	12MM LARGE ROUND WASHERS
A	2	16x50 BOLTS, NUTS & GRIP WASHERS
B	4	12x40 BOLTS, NUTS & GRIP WASHERS
C	2	12x70 BOLTS, NUTS & GRIP WASHERS
D	4	10x35 BOLTS & GRIP WASHERS
E	4	10MM CENTRAL CAPTIVE NUTS

Contents

CB	1	CROSSBAR
CS	1	CENTRE STRUT
PL	2	PLATES

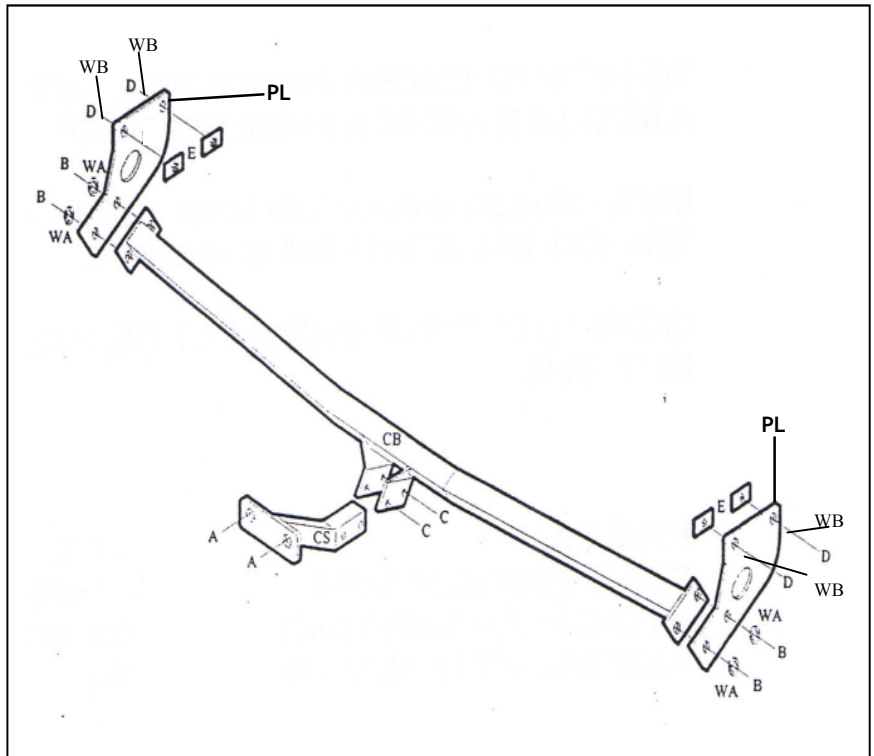

1. REMOVE REAR EXHAUST HANGER RUBBER. INSERT CAPTIVE NUTS E INTO THE CHASSIS (ACCESS VIA THE HOLES ON UNDER SIDE OF CHASSIS). ATTACH PLATES PL TO CAPTIVE NUTS E WITH BOLTS D. AND WASHERS WB
2. ATTACH CROSSBAR CB TO PLATES PL USING BOLTS B AND WASHERS WA.
3. ATTACH CENTRE STRUT CS TO CROSSBAR CB USING BOLTS C.
4. CHECK AND TIGHTEN ALL BOLTS AND RE-FIT THE REAR EXHAUST HANGER RUBBER.

PLEASE REFER TO YOUR VEHICLE HANDBOOK FOR THE MAXIMUM TOWING WEIGHT

All A1 towbars are finished using an anti-corrosive primer. To maximise the appearance of your towbar, and minimise corrosion, we recommend that you regularly inspect and repaint it, especially in exposed areas.

A1 Towing Limited, Parkway Link, Kettlebridge Road, Sheffield, S9 3AJ

T: 0800 404 7070 F: 0845 30 10 476 E: technicalsupport@a1-tow.com

www.a1-tow.com